

MECONTROL Air/Flue Gas

Is characterized by following advantages:

- Absolute measurement across a representative cross section of the air/gas duct.
- Unaffected by the flow pattern and type of the gaseous fluid.
- Easy on-line configuration without reference measurement (e.g. no Pitot tube).
- Accuracy unaffected by dust content or fouling effects.
- Sensor designed to operate under high temperatures and pressures.
- Simple sensor installation and replacement does not require calibration.
- IPC based system provides high reliability and optional integration into the plant DCS.
- No pressure drop, No drift.

Air Measurement	Cross Correlation
Measurement Cycle:	4 sec
Measurement Accuracy:	2% (repeatability)
Measurement Range Velocity:	15 – 225 ft/s
Temperature Range Medium:	50°F - 752°F (standard sensor); - 2000°F (high temperature sensor)
Temperature Range Cabinet:	50°F - 80°F (Option: cooling with air conditioner)
Channels per Cabinet:	4, 8, 16, 32, or 48 (portable option for 4)
Sensors per Channel:	2
Distance of Sensors to the Cabinet:	3000 ft
Data Communication:	Standard output per channel: 1 x 4-20 mA (velocity) Optional input per channel: temperature, pressure Modem, MODBUS (other interfaces available upon request)
Error Contacts:	Switching contact (cabinet fault) Fault contact per measurement channel
Measurement Cabinet:	IP 55, NEMA 12
Dimensions of Cabinet/Weight:	16 channels: h 55" x w 31.5" x d 23.6" /551 lbs 32 channels: h 78.7" x w 63.0" x d 23.6" /772 lbs (other dimensions available)
Power Supply:	1ø, 110 VAC, 60 Hz

PROMECON

Prozess- und Messtechnik Conrads GmbH
Steinfeldstraße 3
D-39179 Barleben/Germany
Phone +49 - 3 92 03 - 8 17 30
Fax +49 - 3 92 03 - 8 17 39
info@promecon.com
www.promecon.com

**PROMECON
USA**

314 Collins Blvd.
Orrville, Ohio 44667
Phone 330-683-9074
Fax 330-683-9082
www.promecon.us

MECONTROL

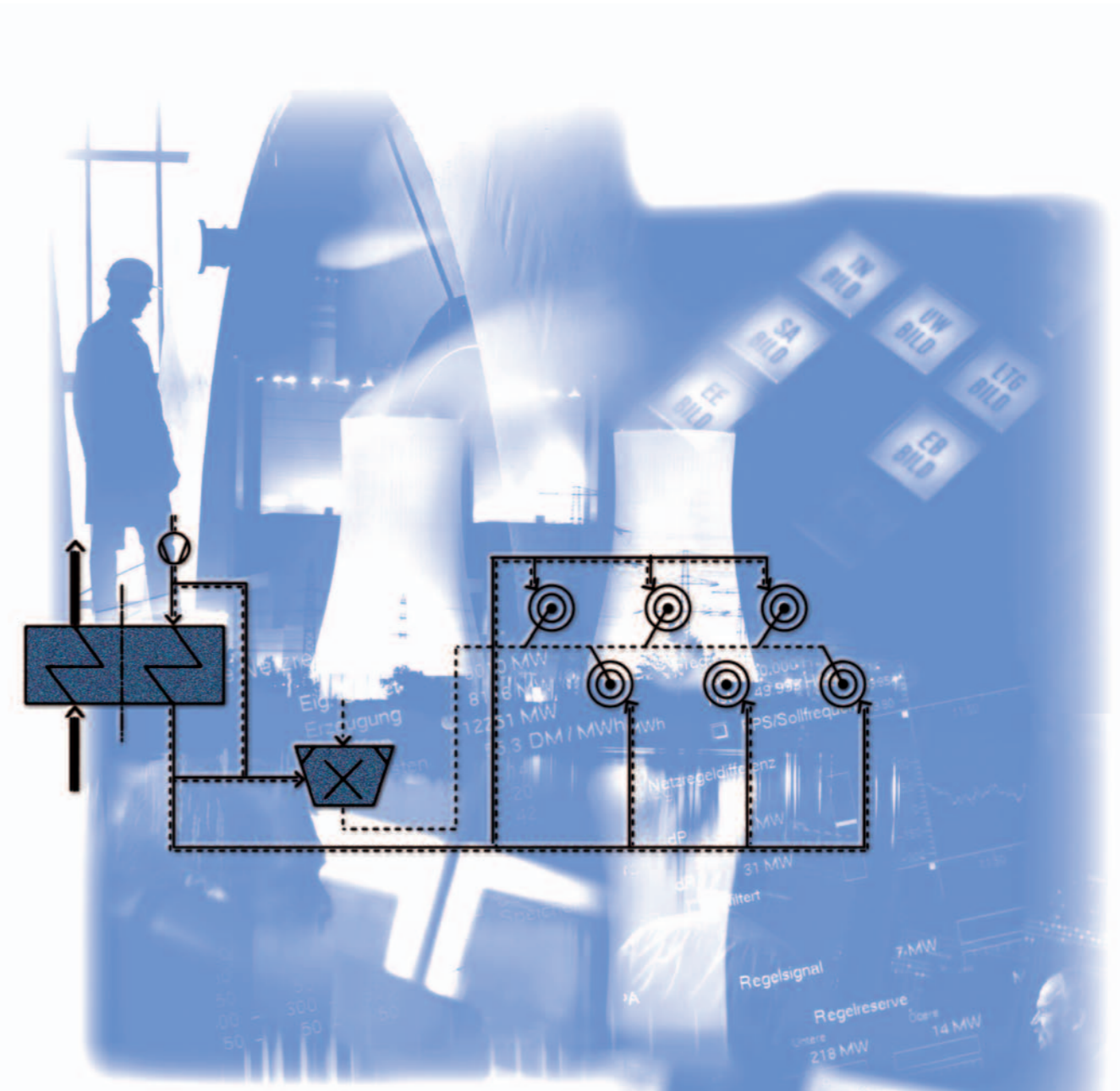

Air/Flue Gas

Air/Flue Gas

NO DETRIMENTAL EFFECTS FROM FLY ASH/DUST

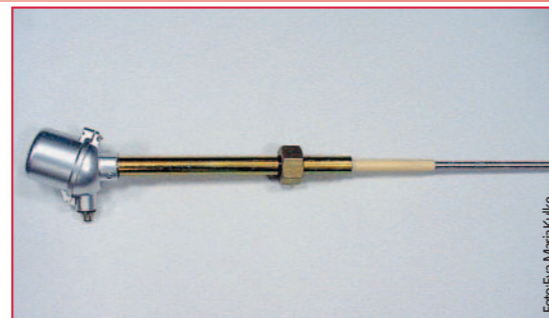

MECONTROL Air Sensor

- **Power Plants:** Primary, Secondary, Overfire Air, etc.
- **Cement Industry:** Tertiary air, raw mill exhaust, cement mill air flow, primary air/coal velocity, cyclone preheater bypass, air from grate cooler, baghouse broken bag detection, preheater downcomer or riser
- **Steel Mills & Other Industries:** Most dusty air streams



MECONTROL Air Installation

Application

The MECONTROL Air measurement is also designed to replace existing Venturi or other differential pressure systems because of its maintenance-free construction and the advantage of installation without any additional provisions and reconstruction measures. Most importantly: it does not need any reference measurement to be calibrated. Measurement can be achieved in difficult applications that were previously not possible.

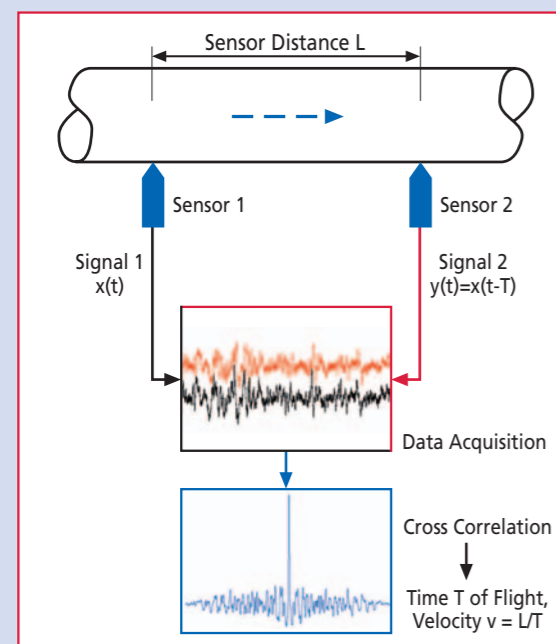

On Line Air Flow Measurement

MECONTROL Air determines the absolute velocity of air or flue gas within pipes or ducts, even under extreme operating conditions and also in high dust atmospheres.

The velocity measurement is performed by a pair of sensors aligned parallel to the longitudinal axis of the pipe. Electrical signals created by (dust) particles at this pair of upstream/downstream sensors are cross correlated and referenced by their time shift. By using the cross sectional area of the duct as well as the temperature and pressure information the gas STP-volume flow can be calculated on line.

System Integration

MECONTROL Air is a rugged and accurate technology. The signals are detected at the individual pipe sensor pairs. In various configurations the measuring cabinet can monitor from 4-48 pipes. Other operating data, such as temperature and pressure can be recorded and processed by the industrial PC for evaluation purposes. The interface provides various output formats to the DCS and is also equipped with a communication port for on-line service and remote configuration. Simple installation can be performed on-line in most cases. Sensor rods are solid stainless steel.

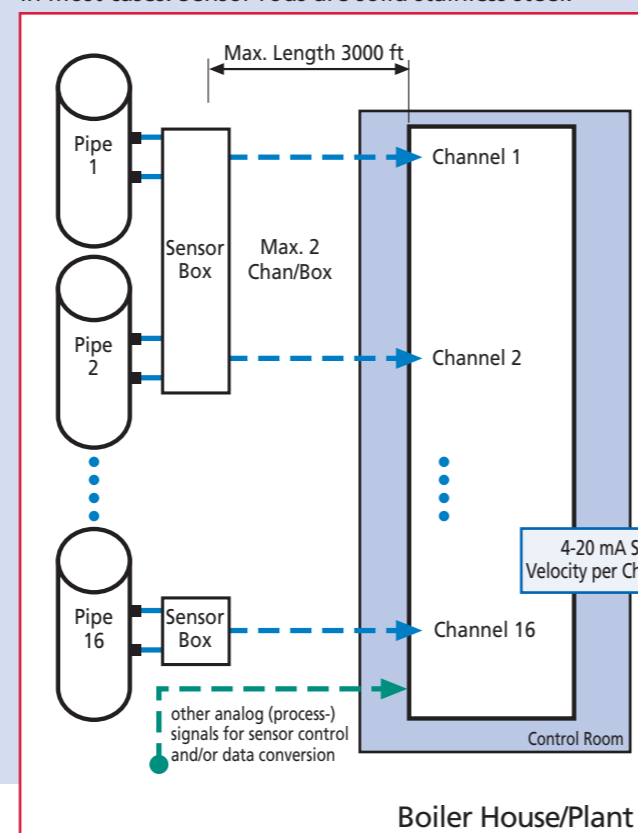

Accuracy

MECONTROL Air provides reliable and repeatable information on velocity. It provides accurate information independent from the flow pattern of the turbulent gas flow and is typically unaffected by the measurement location. In a direct comparison with a typical Pitot measurement in a closed loop pipeline MECONTROL Air proves higher accuracy because of its negligible sensitivity to the approach flow angles.

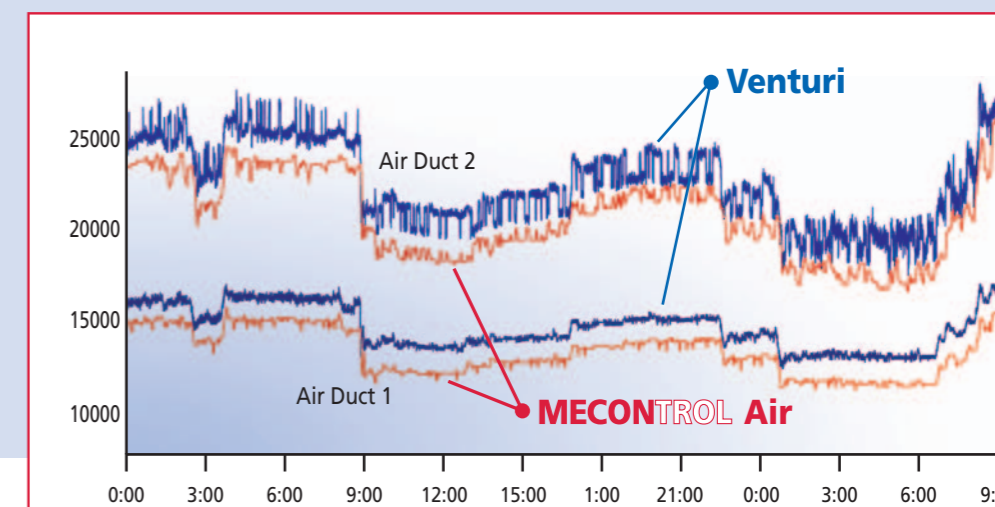
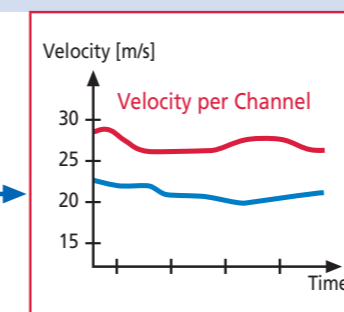
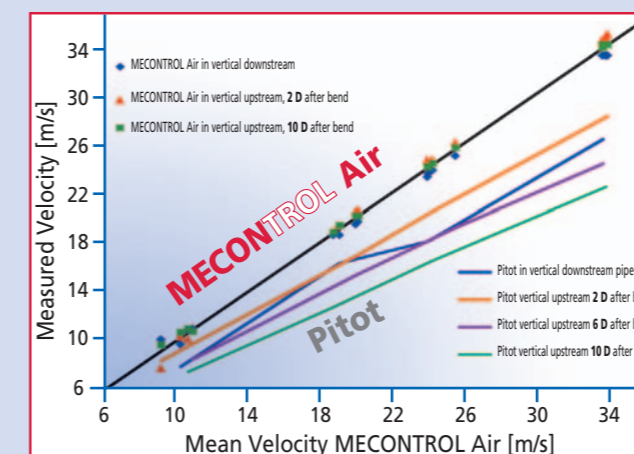

Operating Example